



# WASP HIGHLY SECURE REMOTE CONTROL SYSTEMS

- Complete FM Remote Control System
- 1 . 3 Channels
- 12 / 24Vdc Supply
- High Security  Protocol
- Easy Learn Feature
- Easy Installation Via Screw Terminals.
- Up to 7 Transmitters per System
- Relay Outputs 5A @ 230Vac
- Momentary or Latching Outputs
- Robust Enclosure
- FCC / CE Compliant
- Range up to 100 Metres



## Description

A versatile general purpose remote control, which can be used for controlling many different applications. The system utilises the highly secure Keeloq code hopping protocol to ensure reliable operation.

Easy to install, the receiver is connected using standard screw terminals provided. Power to the receiver is 12 or 24Vdc and the output(s) can switch up to 5A at 230Vac.

The receiver outputs operate when the transmitter switch is pressed. The outputs can be set to momentary or latching operation.

The system is supplied ready to plug and play in addition a further 6 transmitters can be learnt by the receiver.

## Remote Control System

Part Number	Description	Freq (MHz)	Range** (Metres)
WASP-S1	Remote Control System 1 sw	433.92	100
WASP-S2	Remote Control System 2 sw	433.92	100
WASP-S3	Remote Control System 3 sw	433.92	100

## Additional AM Transmitter Keyfobs

Part Number	Description
HORNET-TX1	Transmitter Keyfob 1 switch
HORNET-TX2	Transmitter Keyfob 2 switch
HORNET-TX3	Transmitter Keyfob 3 switch

\*\* Range stated is optimum, direct line of sight. In worst conditions this can be reduced.

## Data Outputs

Each output relay provides an isolated switch. Outputs 2 to 4 Connections are Common (COM) and Normally Open (NO) which close together when activated. Output 1 has an additional Normally Closed (NC) changeover contact.

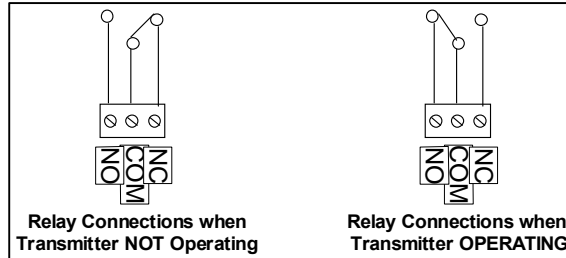

The action of the relay outputs is set by the Option link setting Jumper. A link is made / removed by the small shorting link placed over the pin header.

Option Link 1 Fitted = Momentary Operation  
 Option Link 1 Not Fitted = Latching Operation

Please Note: The relay contacts in this unit are for functional use only and must not be used for isolation purposes

## Option Links

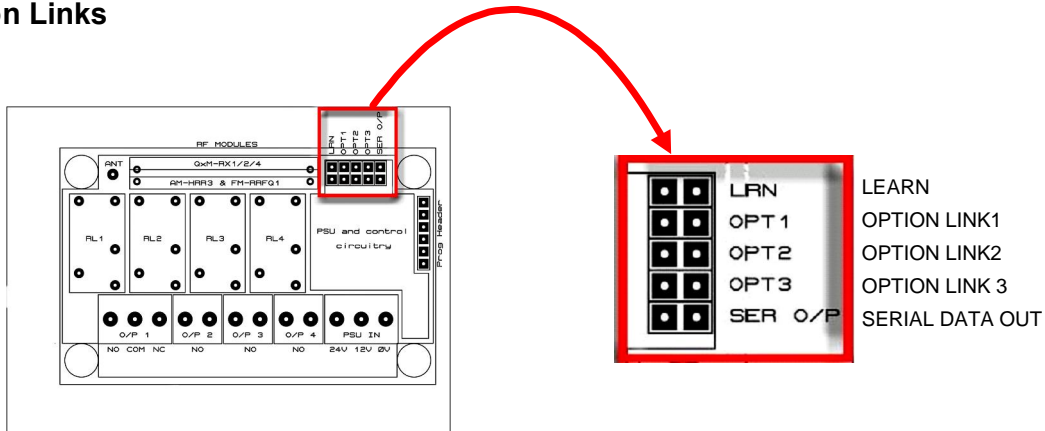

## To Learn a New Transmitter switch follow this procedure

Any transmitter button can be learnt to one or many of the receiver output relays. Each button must be learnt to each relay individually by following this procedure:

1. Select the receiver output relay to learn to:
  - a. Briefly short the LRN (Learn) pins once
  - b. The Learn LED will flash once to indicate output relay 1 is selected
  - c. After the LED stops flashing, press the short the LRN pins again to select the next relay channel
  - d. Repeat step c until the required output relay is selected.
2. Press the button on the transmitter you want to learn to the relay output.
3. The Learn LED will then illuminate, press the same transmitter button again.
4. The Learn LED will then flash to indicate learning is complete.
5. To test the operation, press the transmitter button again and you will hear the relay click as it operates.



# WASP HIGHLY SECURE REMOTE CONTROL SYSTEMS

## Erasing Receivers Memory

1. Short the LRN (Learn) pins for approx 10 seconds.
2. When the Learn LED turns OFF all memory is erased
3. This is factory default state which is indicated by all output LEDs flashing together.

**NOTE:** You cannot erase individual Tx encoders

## Technical Specifications

### Transmitter Keyfob

Battery Type GP23AE (supplied)

Electrical Characteristics	Min	Typical	Max	Units
Supply Voltage	8.5	9	16	Vdc
Supply Current : Quiescent		0		mA
Supply Current : Transmitting		8		mA
Operating frequency		433.92		MHz

### Receiver Decoder

Dimensions 96mm x 55mm x 29mm

ELECTRICAL CHARACTERISTICS		MIN	TYPICAL	MAX	DIMENSION
Supply Voltage	for +12Vdc	11	12	13	Vdc
	for +24Vdc	23	24	25	Vdc
Supply Current:	Quiescent		14		mA
	All relays operating		140		mA

[sales@quasaruk.co.uk](mailto:sales@quasaruk.co.uk)

[www.quasaruk.co.uk](http://www.quasaruk.co.uk)