



KEYFOB TRANSMITTER ENCODERS RADIO / INFRA-RED

- Highly Secure  Protocol
- Available as AM, FM Radio or Infra Red
- 1 – 3 Switch Options
- Led Indication of Transmission
- Directly Compatible With Keeloq Decoder
- Power Saving Auto Shut Off Feature
- Automatically Transmits Battery Low Condition.
- User Customisable Housing
- Board Level Programming of ID
- Range:
 - ⇒ AM-315MHz Up to 50m
 - ⇒ AM-433MHz Up to 100m
 - ⇒ FM-433MHz Up to 150m
 - ⇒ Infra Red Up to 20m
- 433MHz version CE Compliant for use in Europe
- 315MHz FCC Compliant for use in USA



DESCRIPTION

The RF Solutions KEELOQ range of miniature pocket Keyfob encoders are available as Radio or Infra Red transmitters.

When paired with one of the KEELOQ Rx decoder boards, a complete remote control system may be achieved, with comprehensive interfacing capabilities. This may also be high security “code hopping”

The keyfobs are housed in a tough ABS enclosure and supplied with Battery ready to operate.

An membrane overlay sticker is used to indicate the switch positions which may be customised to incorporate a specific logo or mark.

BLOCK DIAGRAM

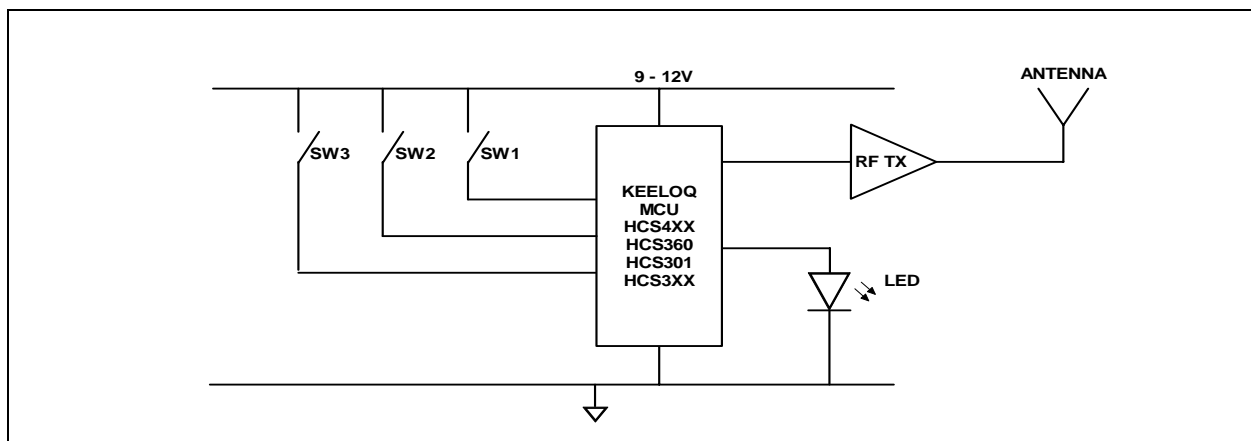



KEYFOB TRANSMITTER ENCODERS RADIO / INFRA-RED

'120' Series FM Keyfob Encoders

Part Number	Description	Freq (MHz)	Range** (Metres)	Compatible Rx Decoders
120T1-433FR1	FM Tx Keyfob 1 Sw	433.92	150	FM-RRFQ1-433 & RF600D HiRK-433FR1 118Cx-433FR1 008-433FR4 009-433FR1 105-433FR2 001B-433FR2 0011-433FR2
120T2-433FR1	FM Tx Keyfob 2 Sw	433.92	150	
120T3-433FR1	FM Tx Keyfob 3 Sw	433.92	150	

'110' Series AM Keyfob Encoders

Part Number	Description	Freq (MHz)	Range** (Metres)	Compatible Rx Decoders
110C1-315AR1	AM Tx Keyfob 1 Sw	315.0	50	AM-RRS3-315 & RF600D AM-HiRK-315 008-315AR1 009-315AR1
110C2-315AR1	AM Tx Keyfob 2 Sw	315.0	50	
110C3-315AR1	AM Tx Keyfob 3 Sw	315.0	50	
110C1-433AR1	AM Tx Keyfob 1 Sw	433.92	100	AM-RRS3-433 & RF600D HiRK-433AR3 118C3AR5 001B-433AR2 0011-433AR1 AM-008C3B-433 009C2-433AR1 AM-105C3A-433
110C12433AR1	AM Tx Keyfob 2 Sw	433.92	100	
110C3-433AR1	AM Tx Keyfob 3 Sw	433.92	100	

'106' Series Infra Red Keyfob Encoders

These products use the HCS360 Keeloq Encoder Device

Part Number	Description	Freq (KHz)	Range** (Metres)	Compatible Rx Decoders
IR-106C1	IR Tx Keyfob 1 Sw	40	20	U105R2
IR-106C2	IR Tx Keyfob 2 Sw	40	20	
IR-106C3	IR Tx Keyfob 3 Sw	40	20	

** Range stated is optimum, direct line of sight. In worst conditions this can be reduced by upto 50%



KEYFOB TRANSMITTER ENCODERS RADIO / INFRA-RED

Mechanical Details

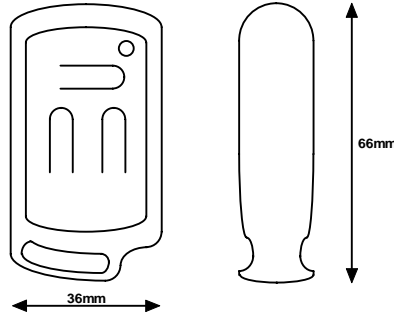

Operation

The Tx encoder transmits the KEELOQ code for as long as any push-button switch is depressed. Operation of the Tx encoder buttons will cause either a momentary or a latching action at the Rx decoder, depending on the configuration of the Rx decoder.

Battery Supply

The keyfob is supplied with a standard cigarette lighter 12V battery type GP23A or equivalent.

Low Battery

When the unit measures a low battery voltage level, the data transmitted includes a 'Low battery' status flag to the receiver decoder.

Auto Shutoff Feature

After ~26seconds of continuous transmission the Keyfobs are programmed shut down. This is to prevent the battery being drained through accidental operation (i.e. if it is in the users pocket!). This is a factory set feature which can be changed on request.

License Exemption

Europe: The transmitter encoders use ECM compliant radio transmitter modules and comply with ETSI330-220 and ETSI300-683.

USA: This device complies with part 15 of the FCC Rules.

Operation is subject to the following two conditions:

1. This device may not cause harmful interference, and
2. This device must accept any interference received, including interference that may cause undesired operation."

Technical Specification

Max Storage Temperature -10°C to +70°C, Max Operating Temperature 0°C to +55°C

Electrical Characteristics	Min	Typical	Max	Dimension
Supply Current (Transmitting)	9	12	16	mA
Frequency 315MHz version		315.00		MHz
Frequency 433MHz version	432.90	433.920	434.100	MHz
Output Power (ERP) @ 433.92 MHz			10	mW





KEYFOB TRANSMITTER ENCODERS RADIO / INFRA-RED

Building a Receiver

Any of the keyfob Tx Encoders may be decoded with one of the complete RF Solutions receiver decoders or by using the appropriate receiver and RF600 decoder I/C. Schematic design is given in the datasheet for RF600 (DS600)

Further Information: Developing a Keeloq Based Decoder System

The RFEVAL2 is an Evaluation Kit consisting of a several transmitter encoders and receiver decoder board. This kit provides a hardware development platform capable of accepting a variety of radio modules and antennae to enable the engineer to develop a Remote Telemetry application.

The kit provides a hardware development platform for:

- Embedding Telemetry
- Producing a Decoder with RS232 Output
- Range Testing
- Target Environment Testing
- Antenna Evaluation

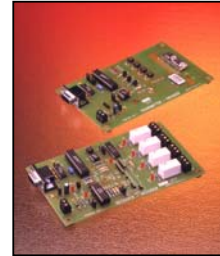

This enables the engineer to select the optimum radio modules, antenna type and get a radio application working with the minimum time. Please see Datasheet DS123 Full schematics and parts list supplied.

**R. F. Solutions Ltd.,
Unit 21, Cliffe Industrial Estate,
Lewes, E Sussex, BN8 6JL, England
Tel +44 (0)1273 898 000 Fax +44 (0)1273 480 661
Email sales@rfsolutions.co.uk
<http://www.rfsolutions.co.uk>**

R F Solutions is a member of the Low Power Radio Association.

All Trademarks acknowledged and remain the property of the respected owners.

Information contained in this document is believed to be accurate, however no representation or warranty is given and R.F. Solutions Ltd. assumes no liability with respect to the accuracy of such information. Use of R.F.Solutions as critical components in life support systems is not authorised except with express written approval from R.F.Solutions Ltd.