

'102 SERIES RADIO / IR ENCODER TRANSMITTERS

- Highly Secure  Protocol
- QM, FM or Infra Red
- Frequency Options: 315, 433 or 916MHz
- LED Indication Of Transmission
- 1,2 or 4 Switch Versions Expandable To 15
- Power Saving Auto Shut Off Feature
- Automatically Transmits Battery Low Condition
- IP40 Rated Enclosure
- User Customisable Overlay
- Board Level Programmable
- 315MHz versions FCC Compliant
- 433MHz versions EMC Compliant



Note: Standard FM units Shown, narrowband FM transmitters include external ¼ wave whip antenna

The RF Solutions 102 range of transmitter encoders are available as either FM, FMNB radio or Infra Red. The encoders use the KEELOQ encryption algorithm providing the worlds most advanced high security protocol. Each encoder may be used with one of RF Solutions decoders, or with one of the KEELOQ decoder I/C's.

Alternatively, the user may decode the KEELOQ algorithm and embed within a PIC Microcontroller. (Please see datasheet DS600).

When paired with one of the KEELOQ Rx decoder boards, a complete high security "code hopping" remote control system may be achieved. The transmitter is supplied as a complete product with battery ready to operate (PP3). Each encoder can be board level programmed with a specific manufacturer's ID code if required

Custom solutions may also be supplied unique to customer specific requirements. Please contact RF Solutions for further information.

Block Diagram

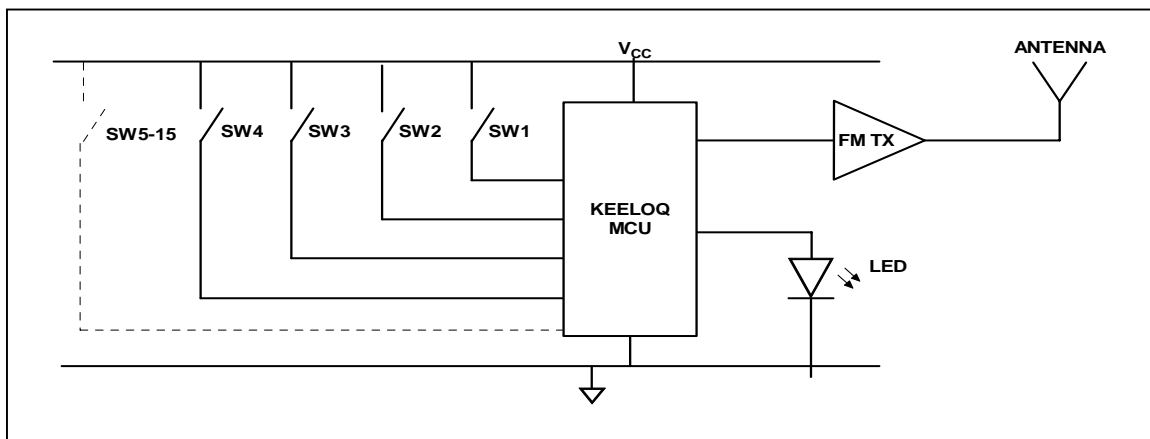



'102 SERIES RADIO / IR ENCODER TRANSMITTERS

Low Battery

When the unit measures a low battery voltage level, the data transmitted includes a 'Low battery' status flag to the receiver decoder.

Power Supply

The circuit has been designed to operate from a single PP3 battery supply. This will provide in excess of 1,000,000 transmissions.

Note: reverse voltage polarity connection may cause damage to the circuit.

License Exemption (Radio Transmitters)

Europe: The transmitter encoders use ECM compliant radio transmitter modules and complies with ETSI330-220 and ETSI300-683.

USA: This device complies with part 15 of the FCC Rules.

Operation is subject to the following two conditions:

1. This device may not cause harmful interference, and
2. This device must accept any interference received, including interference that may cause undesired operation."

KEELOQ Protocol Configuration

Each encoder is supplied ready programmed with a unique random serial number. The decoder has the ability to memorise this serial number using a simple learn procedure (please see decoder datasheet).

How does KEELOQ technology work?

KEELOQ is based on a code hopping algorithm which provides Rock Solid Security. KEELOQ uses a programmable 64-bit encryption key that is unique to each device to generate 32-bit hopping code. The key length and hopping code combination reduces the possibility of unwanted access, due to code grabbing and code scanning, to essentially zero. Such CIA-like levels of security are desirable, but many manufacturers would expect them to be cost-prohibitive. KEELOQ offers the solution for affordable, Rock Solid Security that is the future of technology for the cars, homes and offices we wish to protect.

Adding Additional Switches

Additional switches may be added through Connector J3. The four connections of J3-1, 2, 3, & 4 represent the four input lines to the HCS360 encoder device. These may be connected to a binary coded decimal (bcd) input to obtain 1 of 16 states.

In addition to this, J3-7 = 5Vdc and J3-8, 9, 10 = GND.

Absolute Maximum Ratings

Supply Voltage (V _{CC} to GND)	+5.5 to +15.8 Volts
Storage Temperature	-10°C to +70°C
Operating Temperature	0°C to +55°C
Dimensions	110mm x 65mm x 24mm

Electrical Characteristics	Min	Typical	Max	Dimension
Supply Voltage	8	9	12	V
Supply Current	11	14	21	mA
Frequency				
315MHz FM		315.00		MHz
433MHz QM / FM Wideband		433.92		
433MHz FM Narrow band	434.500	434.525	434.550	
915MHz Narrow band	914.50	914.50	914.50	
RF Output Power (ERP) @ 433 MHz	-		10	mW





'102 SERIES RADIO / IR ENCODER TRANSMITTERS

'FM102' QM Series Encoders (Red Transmit LED)

Part Number	Description	Freq (MHz)	Range** (Metres)	Compatible Decoders
102C1-433Q	QM Encoder 1 Sw	433.92	150	FM-001B-433 FM-0011-433 008-433Q U105
102C2-433Q	QM Encoder 2 Sw	433.92	150	
102C4-433Q	QM Encoder 4 Sw	433.92	150	

'FM102' FM Series Encoders (Yellow Transmit LED)

Part Number	Description	Freq (MHz)	Range** (Metres)	Compatible Decoders
102C1-315F	FM Encoder 1 Sw	315	200	008-315F
102C2-315F	FM Encoder 2 Sw	315	200	
102C4-315F	FM Encoder 4 Sw	315	200	
102C1-433F	FM Encoder 1 Sw	433.92	200	001B-433F 0011-433F 008-433F 105-433F
102C2-433F	FM Encoder 2 Sw	433.92	200	
102C4-433F	FM Encoder 4 Sw	433.92	200	
102C4-433F	FM Encoder 4 Sw	433.92	200	

'FM102' Narrow Band Series Encoders (Red Transmit LED)

Part Number	Description	Freq (MHz)	Range** (Metres)	Compatible Decoders
102C1-525N	FM Narrow Band Enc 1 Sw	434.525	1000	105-433NB
102C2-525N	FM Narrow Band Enc 2 Sw	434.525	1000	
102C4-525N	FM Narrow Band Enc 4 Sw	434.525	1000	

'IR102' Series Infra-Red Encoders (Red Transmit LED)

Part Number	Description	Range** (Metres)	Compatible Decoders
102C1-IR3	Infra Red Encoder 1 Sw	20	U105
102C4-IR3	Infra Red Encoder 4 Sw	20	

Should you require further assistance please contact:

R. F. Solutions Ltd.,
Unit 21, Cliffe Industrial Estate,
South Street,
Lewes,
E Sussex, BN8 6JL, England

Tel +44 (0)1273 898 000 Fax +44 (0)1273 480 661

Email sales@rfsolutions.co.uk <http://www.rfsolutions.co.uk>

R F Solutions is a member of the Low Power Radio Association.

All Trademarks acknowledged and remain the property of the respected owners.

Information contained in this document is believed to be accurate, however no representation or warranty is given and R.F. Solutions Ltd. assumes no liability with respect to the accuracy of such information. Use of R.F.Solutions as critical components in life support systems is not authorised except with express written approval from R.F.Solutions Ltd.